



BF-300



Machine de Production de Boules de Fibre



PRODUIT TRAITÉ

Fibre Standard et
Microfibre



CARACTÉRISTIQUES DE LA PRODUCTION

Diamètre de la boule de
fibre personnalisable



CONFIGURATION DE LA MACHINE

Double rotor avec
collecteur de poussière et
couverture d'isolation
acoustique



BF-300

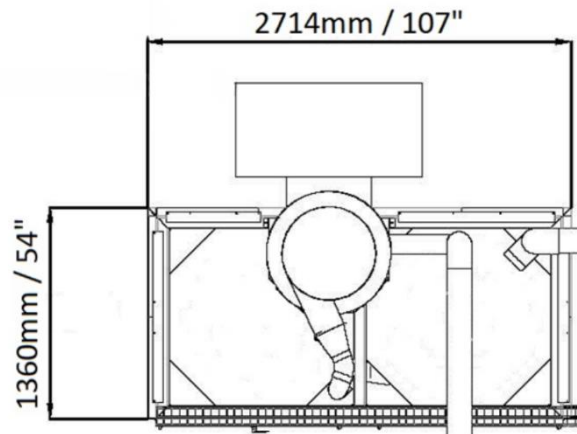
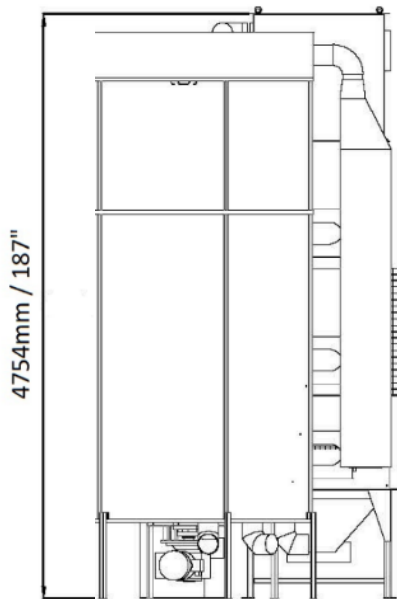

	Larg (mm/ft)	2714 / 8.9		V	400 / 480
	Long (mm/ft)	1360 / 4.5		Hz	50/ 60
	A (mm/ft)	4754 / 15.6		Phases	3Ph+N+G
	Kg/lb	2490 / 5490		kW	42
				Bar/psi	6/87
				NI/cfm	9 / 0.05
				Air sec / Non lubrifié	
CODE DES MARCHANDISES		84451100			
CONFORMITÉ CE		2006/42/CE, 2004/108/CE, 2006/95/CE and modifications			

Pour en savoir plus sur nos solutions de traitement des matières premières, [cliquez ici](#).

Pour la configuration de la machine, les performances et les prix, contactez-nous : sales@brighigroup.com