



BV-100



## CABIN SYSTEM TO FILL TNT OR NYLON SACKS



### **PRODUCT PROCESSED**

fiber and microfiber, wool,  
natural fibers, shredded  
foam, ball fiber, recycled  
fiber and fabric waste



### **MACHINE CONFIGURATION**

1 Cabin. Other  
configurations available for  
higher capacity



### **OUTPUT FEATURES**

Customizable filling  
capacity depending on  
selected aspirator



## BV-100

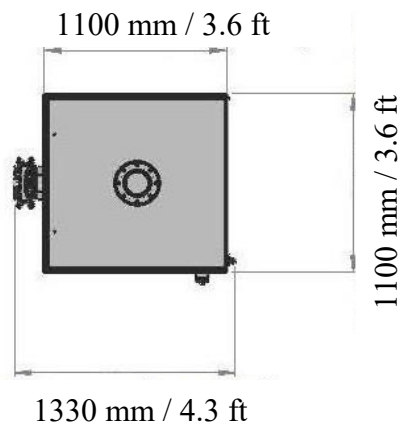
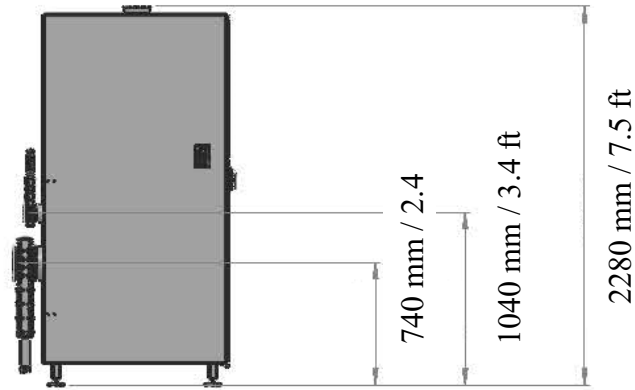

	W (mm/ft)	1100 / 3.6		V	400 / 480	
	L (mm/ft)	1330 / 4.3		Hz	50 / 60	
	H (mm/ft)	2280 / 7.5		Phases	3Ph+G	
	Kg/lb	450 / 990	kW			6
	COMMODITY CODE	84459000				
CE CONFORMITY	2006/42/CE, 2004/108/CE, 2006/95/CE and modifications					

To learn more about our raw material processing solutions, click [here](#)

For machine configuration, performances and prices contact us:  
[sales@brighigroup.com](mailto:sales@brighigroup.com)