



# EP-500 EASY PILLOW



## Automatic Pillow Stuffing, Sewing and Labelling System



### **PRODUCT PROCESSED**

Rolled carded fiber batts and foam cores



### **PRODUCT SIZE & WEIGHT**

From 400mm x 400mm (16" x 16") up to 650mm x 900mm (25 1/2" x 36")







### **STITCH TYPE**

Overlock (3 Threads - 1 needle or 4 Threads - 2 needles)

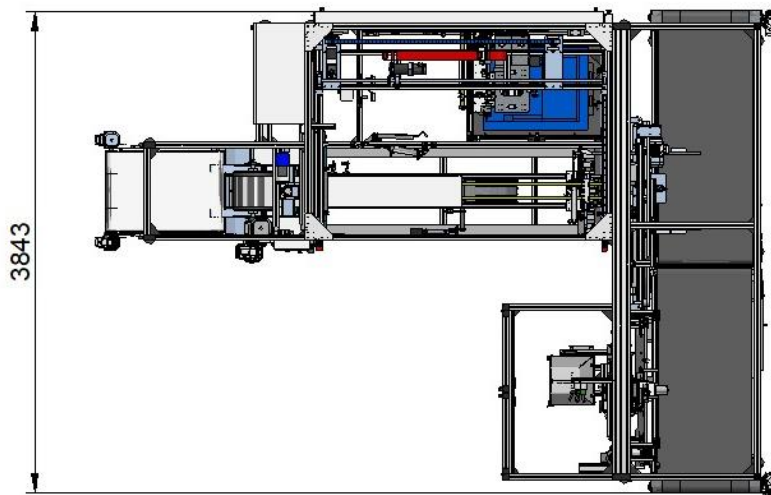
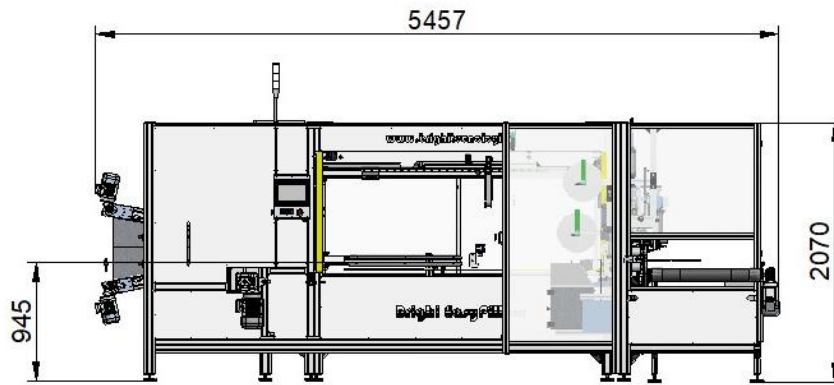

EP-500 EASY PILLOW – 1 SEWING STATION



	W (mm/ft)	5208/ 17 <sup>3</sup> / <sub>32</sub>		V	400/480
	L (mm/ft)	5457/ 17 <sup>29</sup> / <sub>32</sub>		Hz	50/ 60
	H (mm/ft)	2070/ 6 <sup>5</sup> / <sub>64</sub>		Phases	3Ph+N+G
				kW	11
				Bar/psi	6/87
				NI/cfm	910/5.36
			Dry Air / Not Lubricated		
COMMODITY CODE		84522100			
CE CONFORMITY		2006/42/CE, 2004/108/CE, 2006/95/CE and modifications			



# STUFFING & SEWING

**EP-500**



Automatic

**EP-400**



Semi-automatic

**HF-100**



Semi-automatic

To learn more about our stuffing solutions, click [here](#)

For machine configuration, performances and prices contact us:

[sales@brighigroup.com](mailto:sales@brighigroup.com)