



HL-400



Feather and Shredded Foam Loader



PRODUCT PROCESSED

Compressed bags and bags of feather & down or shredded foam



MACHINE CAPACITY

1 bag or sack at a time



MACHINE CONFIGURATION

Additional loading belt to increase buffer capacity and efficiency



HL-400

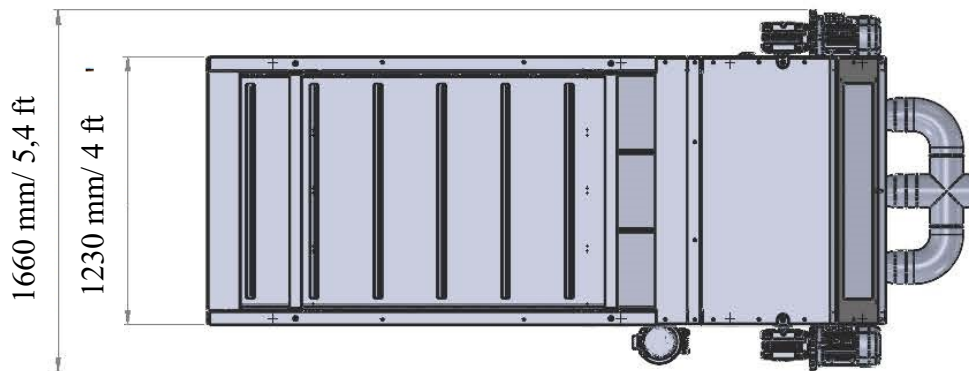
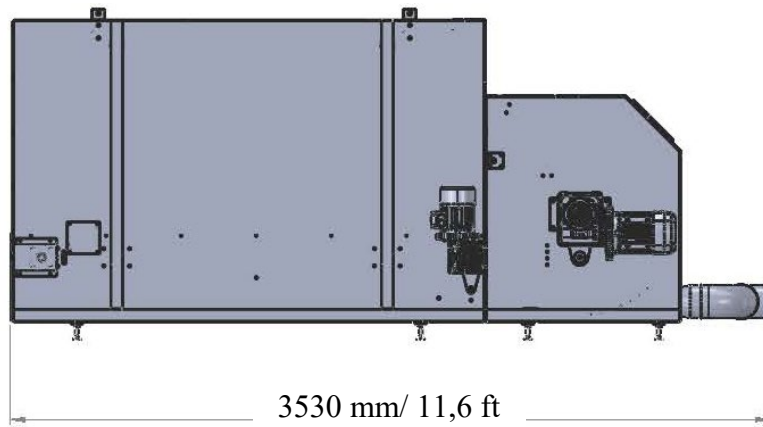

	W (mm/ft)	1660/ 5,4		V	400/480	
	L (mm/ft)	3530/ 11,6		Hz	50/ 60	
	H (mm/ft)	1540/ 5		Phases	3Ph+N+G	
	Kg/lb	1150/ 2025	kW			4
	COMMODITY CODE		84451100			
CE CONFORMITY		2006/42/CE, 2004/108/CE, 2006/95/CE and modifications				

To learn more about our raw material processing solutions, click [here](#)

For machine configuration, performances and prices contact us:
sales@brighigroup.com