



MP-500



## Macchina Impilatrice Automatica



### **PRODOTTO PROCESSATO**

Cuscini, guanciali, trapunte  
piegate



### **DIMENSIONE PRODOTTO**

Da 400mm x 400mm / (16"  
x 16") a 800mm x 800mm  
(32" x 32")



### **CARATTERISTICHE PRODOTTO FINITO**

A partire da 3 prodotti da  
impilare



# MP-500

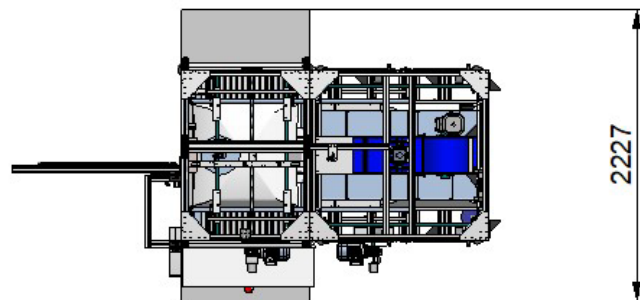
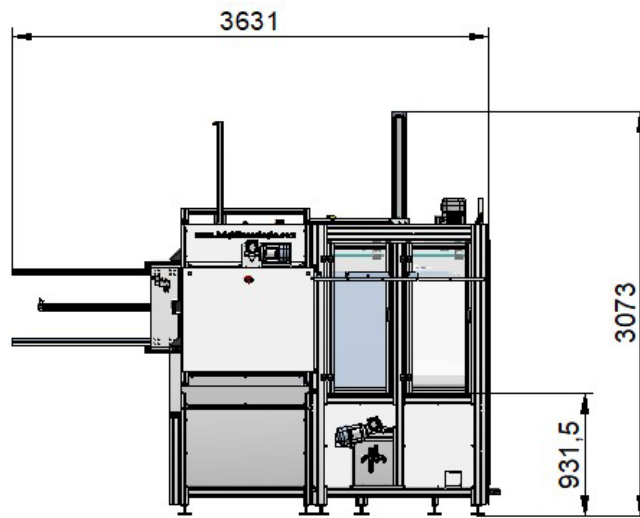

	P (mm/ft)	2227 / 7.3		V	400 / 480
	L (mm/ft)	3631 / 11.9		Hz	50 / 60
	H (mm/ft)	3073 / 10		Fasi	3Ph+N+T
	Kg/lb	1480/ 3263		kW	3.5
				Bar/psi	6 / 87
				NI/cfm	530 / 3.12
				Aria Secca / Non Lubrificata	
CODICE DOGANALE		84224000			
CONFORMITA' CE		2006/42/CE, 2004/108/CE, 2006/95/CE e successive integrazioni.			



# IMPILAMENTO

**MP-500**



**Automatico**  
Multipack

**MP-400**



**Semi-automatico**  
Multipack

**MP-200**

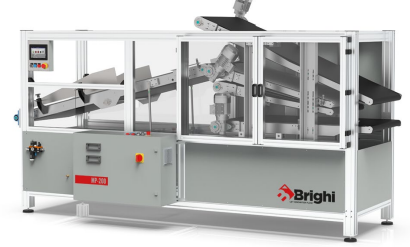

**Automatico**  
Twinpack

Per saperne di più sulle nostre soluzioni per il packaging, fare clic [qui](#)

Per la configurazione delle macchine, le prestazioni e i prezzi contattateci:  
[sales@brighigroup.com](mailto:sales@brighigroup.com)