



SF-300



Fabric and Fiber Waste Opener



PRODUCT PROCESSED

Non-woven fabric, quilted fabric, thermobonded waste and polyester fiber



MACHINE CONFIGURATION

8 stages to process the waste and reopen the fiber



INPUT FEATURES

Possibility to load materials manually through the belt or automatically from the upstream machine

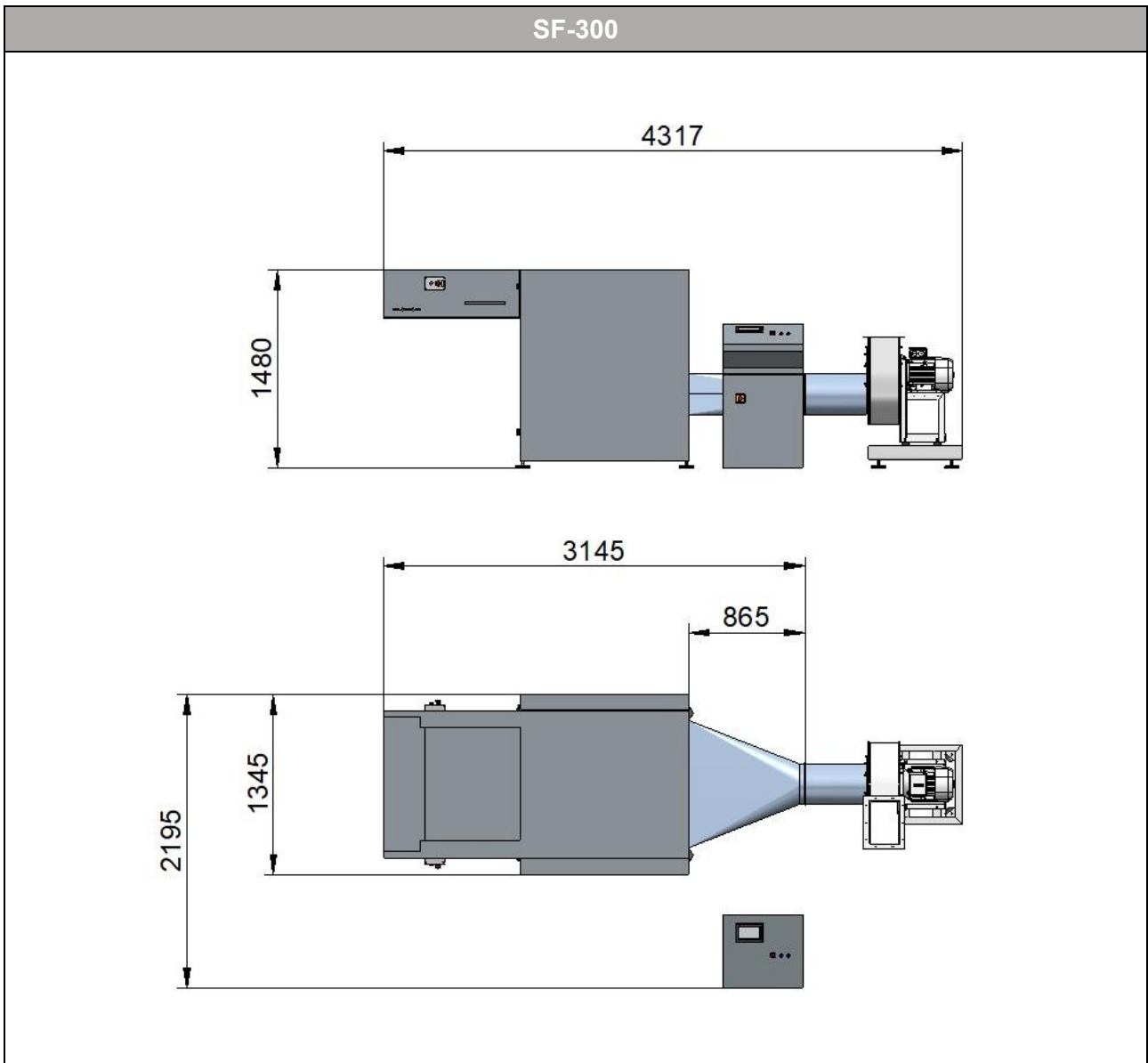

	W (mm/ft)	2195 / 7.2		V	400/480
	L (mm/ft)	4317 / 14.2		Hz	50/ 60
	H (mm/ft)	1480 / 4.9		Phases	3Ph+G
	Kg/lb	1200/ 2646		kW	15.8
COMMODITY CODE		8445 9000			
CE CONFORMITY		2006/42/CE, 2004/108/CE, 2006/95/CE and modifications			

To learn more about our recycling solutions, click [here](#)

For machine configuration, performances and prices contact us:
sales@brighigroup.com